

Hydraulic load cells

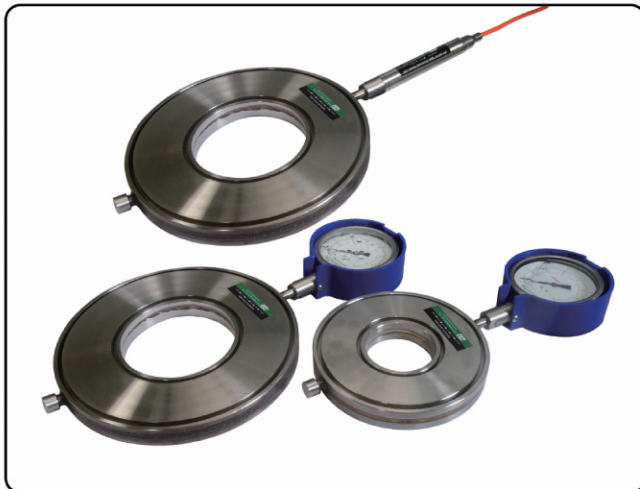

Description

Hydraulic load cells are designed to directly check the capacity of load at the tieback, rock bolt, and timbering wall that are used as the timbering system. The outside of hydraulic load cell is welded by 2nos stainless steel plates these are processed precisely & thinly. And inside of hydraulic load cell is filled with oil after taking out the air. hydraulic load cell is directly connected the pressure sensor of analog type on the main frame of cell and it is revised by our universal testing machine (UTM) for calibrating as ton · f unit. Hydraulic load cell is designed as waterproof structure for obtaining the stable output value for a long-term. And it is designed as Europe type that is optimum to use at the severity site.

In addition, as an option, S(Sensor) type is manufactured by removing the analog type pressure sensor from the standard type and then attaching a vibrating wire pressure sensor to the hydraulic cell.

The S type is issued as a separate calibration certificate, and the frequency is measured by a vibrating wire readout unit and then the load is converted by applying the conversion factor recorded in the calibration sheet.

Applications

Hydraulic load cell can measure the load of acting to the strand, earth anchor, and rockbolt.

Specification

Model	AH50P	AH50R	AH75P	AH75R	AH100P	AH100R	AH150P	AH150R	AH200P	AH200R
Direction of pressure gauge	Parallel	Right angle	Parallel	Right angle	Parallel	Right angle	Parallel	Right angle	Parallel	Right angle
Applied sensor	Analogue manometer									
Rated capacity(ton · f)	50		75		100		150		200	
Weight (kg)	2.5		4.8		7.3		9.8		17.5	
Safe overload	120% FSR									
Resolution	2 ton · f									
Accuracy	± 1.0% FSR									
Material of cell	Stainless steel									
Thermal shift	0.25 FSR /°C									
Operating temperature	-40~60°C									
Weight of bearing plate(2nos/kg)	9.2		12.8		16		22		24	

※ The S type for each model is equipped with a VW pressure sensor instead of the manometer.

Dimensions

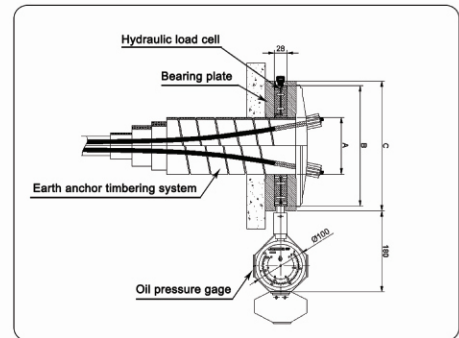

(mm)

Model	AH50	AH75	AH100	AH150	AH200
A	75	100	125	150	125
B	188	228	265	316	337
C	208.5	248.5	285.5	336.5	357.5

Ordering information

- Installation place and application
- Expected design load
- Inner diameter of hyd. cell
- Direction of pressure gauge (P & R type)



[Hyd. manometer]

Features

- High stability and high strength design
- High accuracy maintenance in the eccentric load
- Precision of cell process is under 0.05 (shaking, parallel straightness)
- It shows load directly at gauge so that it is easy to secure the stability at worksite.

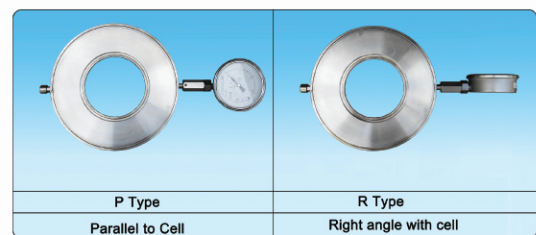

[Direction of pressure gauge]